



Control the Air in your System

LKUV-2 Air-Relief Valve

Concept

LKUV-2 is a reliable, automatic air-relief valve which is installed vertically on the top of a pipeline or container or before the inlet for a pump, where the removal of air is required. Example 1: Bleeding of a pipe line where an air pocket has formed on account of the installation. In this case the valve is installed at the top of the pipe. Example 2: Bleeding of a pipe on the suction side of a pump. The suction side is bled automatically, before the pump starts, establishing a vacuum. Binding of air to the product will be prevented, and hence subsequent cavitation. In this case the valve is installed in front of the pump, on top of the inlet pipe.

Working principle

LKUV-2 is a double-seated valve with a freely moving plastic ball. The ball, which is lighter than water, closes against the upper or lower seat, depending on the pressure conditions.

Standard design

The valve body is in two parts and assembled by means of a clamp. The lower valve body has a welding stub.



TECHNICAL DATA

Pressure

Max. product pressure: 1000 kPa/145 psi (10 bar).

Max. temperature: 90°C/194°F (because of the plastic ball).

Density of ball: 0.906 kg/dm³

PHYSICAL DATA

Materials

Steel parts: Stainless steel AISI 304.

Ball: Material Polypropylene

Product wetted seals: EPDM

Surface finish: Bright

Options

Alternative elastomers:

- NBR (Buna N)
- FPM (SFY)

Note! Important for correct function:

- Product density higher than the ball density.
- Vertical installation.
- Pure products.

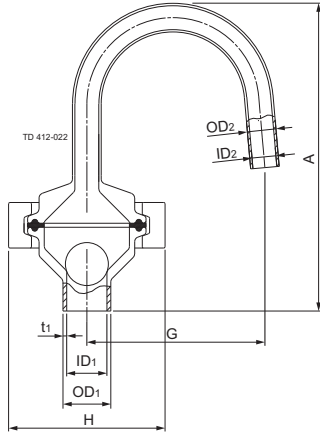

Fig. 1. Dimensions

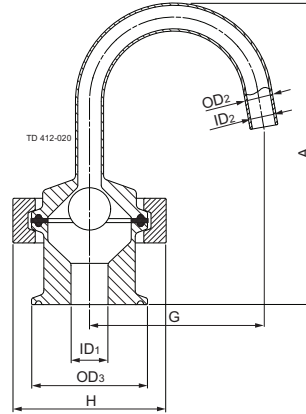
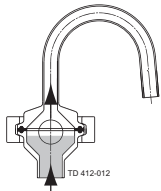

Fig. 2. Dimensions

Dimensions

Dimension	(mm)	(inch)
A	128,7	5.07
G	74,5	2.93
H	58,5	2.57
ID1	15,8	0.66
ID2	10	0.39
OD1	20	0.79
OD2	12	0.47
OD3	49.5	1.95
t1	64.0	2.52
t1	1,6	0.06
Weight	(kg)	(lb)
	0,6	1.32

Situation 1



Pressure conditions

Pressure, air or product, or air/product.

Effect

The ball is lifted from the lower seat. The air can escape until the product lifts the ball against the upper seat, closing the valve.

Situation 2

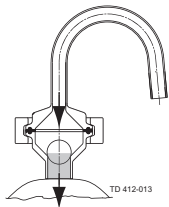

Pressure conditions

Vacuum, air or product, or air/ product.

Effect

The ball moves against the lower seat, closing the valve, whether it contains air or product, or air/product.

Alfa Laval reserves the right to change specifications without prior notification. ALFA LAVAL is a trademark registered and owned by Alfa Laval Corporate AB.

ESE00379ENUS 1505

© Alfa Laval

How to contact Alfa Laval

Contact details for all countries are continually updated on our website. Please visit www.alfalaval.us to access the information direct.