

Metal seated floating ball design valve (Trim 5H)

150UTDZ 5HM, 150SCTDZ 5HM

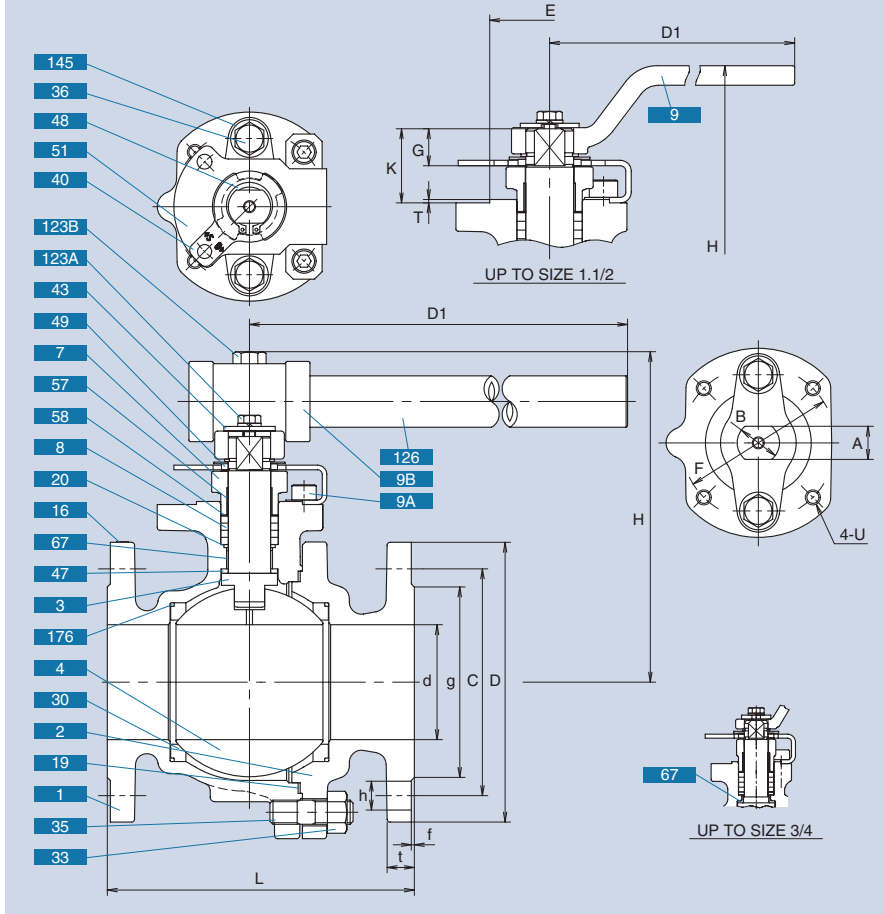

Construction and Materials

No.	Parts	Stainless steel shell	Carbon steel shell
		150UTDZ 5HM	150SCTDZ 5HM
1	Body	A351 Gr.CF8M	A216 Gr.WCB
2	Body cap	A351 Gr.CF8M	A216 Gr.WCB
3	Stem	A564 Type 630	
4	Ball	A276 Type 316 with Cr. plating	
7	Gland	A351 Gr.CF8	
8	Gland packing	Flexible graphite	
9	Handle*1	Ductile iron	
9A	Handle bar*1	Carbon steel	
9B	Handle head*1	Ductile iron	
16	Name plate	A276 Type 304	
19	Gasket	Flexible graphite	
20	Packing washer	A276 Type 316L	
30	Ball seat	A276 Type 316 with Ni-Cr alloy hard facing*2	
33	Cap nut	A194 Gr.8M	A194 Gr.2HM
35	Cap bolt	A193 Gr.B8M	A193 Gr.B7M
36	Gland bolt	Stainless steel	
40	Keylock plate	A276 Type 304	
43	Handle-lock plate	A276 Type 304	
47	Thrust washer	Carbon	
48	Snap ring	A276 Type 304	
49	Stopper	A276 Type 304	
51	Stopper plate	A276 Type 304	
57	Gland bush	Carbon	
58	Gland washer	A276 Type 304	
67	Stem bearing	Carbon	
123A	Handle-lock plate bolt	Stainless steel	
123B	Handle bolt	Stainless steel	
126	Stopper plate bolt	Stainless steel	
145	Coned disc springs	Inconel® 718 or Equivalent	
176	Seat packing	Flexible graphite	

*1) Refer to the following table *2) Equivalent to METCO Type 16C

Operation (Standard)	Class 150
Lever type	Size 1/2 to 11/2
Bar type	Size 2 to 4
Gear	Size 5 to 8

Dimensions:150UTDZ 5HM, 150SCTDZ 5HM

Unit: inch

Nominal size	d	H	D1	L	End flange						Mounting Dimension for Actuator										APPROX. MASS (lb)		
					D	Bolt hole		Bolt size	g	t	f	A	B	E	F	G	K	T	U	ISO5211 Flange Type			
in.						C	NO.	h															
1/2	0.55	4.25	5.12	4.25	3.50	2.38	4	0.62	1/2	1.38	0.44	0.06	0.36	0.47	0.99	1.42	0.35	0.87	0.04	M5	F03	5.73	
3/4	0.75	4.37	5.12	4.62	3.88	2.75	4	0.62	1/2	1.69	0.44	0.06	0.36	0.47	0.99	1.42	0.35	0.87	0.04	M5	F03	6.17	
1	0.95	4.88	6.30	5.00	4.25	3.12	4	0.62	1/2	2.00	0.44	0.06	0.55	0.71	1.38	1.97	0.55	1.18	0.06	M6	F05	9.92	
1.1/4*	1.26	5.04	6.30	5.50	4.61	3.50	4	0.63	1/2	2.52	0.50	0.06	0.55	0.71	1.38	1.97	0.55	1.18	0.06	M6	F05	11.02	
1.1/2	1.50	5.28	9.06	6.50	5.00	3.88	4	0.62	1/2	2.88	0.56	0.06	0.67	0.87	2.17	2.76	0.67	1.34	0.06	M8	F07	18.74	
2	1.97	5.83	11.81	7.00	6.00	4.75	4	0.75	5/8	3.62	0.62	0.06	0.67	0.87	2.17	2.76	0.67	1.34	0.06	M8	F07	25.13	
2.1/2	2.52	8.23	23.62	7.50	7.00	5.50	4	0.75	5/8	4.12	0.69	0.06	0.87	1.10	2.76	4.02	0.87	1.77	0.08	M10	F10	43.43	
3	3.00	8.62	23.62	8.00	7.50	6.00	4	0.75	5/8	5.00	0.75	0.06	0.87	1.10	2.76	4.02	1.06	1.77	0.08	M10	F10	55.12	
4	3.94	9.88	39.37	9.00	9.00	7.50	8	0.75	5/8	6.19	0.94	0.06	1.06	1.42	3.35	4.92	1.06	2.05	0.08	M12	F12	108.03	

* 150UTDZ 5H only.

Dimensions:150UTDZ 5HM, 150SCTDZ 5HM

Unit: mm

Nominal size	d	H	D1	L	End flange						Mounting Dimension for Actuator										APPROX. MASS (kg)		
					D	Bolt hole		Bolt size	g	t	f	A	B	E	F	G	K	T	U	ISO5211 Flange Type			
mm						C	NO.	h															
15	14	108	130	108	89	60.5	4	16	1/2	35	11.2	1.6	9	12	25	36	9	22	1	M5	F03	2.6	
20	19	111	130	117	98	70.0	4	16	1/2	43	11.2	1.6	9	12	25	36	9	22	1	M5	F03	2.8	
25	24	124	160	127	108	79.5	4	16	1/2	51	11.2	1.6	14	18	35	50	14	30	1.5	M6	F05	4.5	
32	32	128	160	140	117	89.0	4	16	1/2	64	12.7	1.6	14	18	35	50	14	30	1.5	M6	F05	5.0	
40	38	134	230	165	127	98.5	4	16	1/2	73	14.3	1.6	17	22	55	70	17	34	1.5	M8	F07	8.5	
50	50	148	300	178	152	120.5	4	19	5/8	92	15.9	1.6	17	22	55	70	17	34	1.5	M8	F07	11.4	
65	64	209	600	190	178	139.5	4	19	5/8	105	17.5	1.6	22	28	70	102	22	45	2	M10	F10	19.7	
80	76	219	600	203	190	152.5	4	19	5/8	127	19.1	1.6	22	28	70	102	22	45	2	M10	F10	25.0	
100	100	251	1000	229	229	190.5	8	19	5/8	157	23.9	1.6	27	36	85	125	27	52	2	M12	F12	49.0	

* 150UTDZ 5H only.

Metal seated floating ball design valve (Trim 5H)

G-150UTDZ 5HM, G-150SCTDZ 5HM

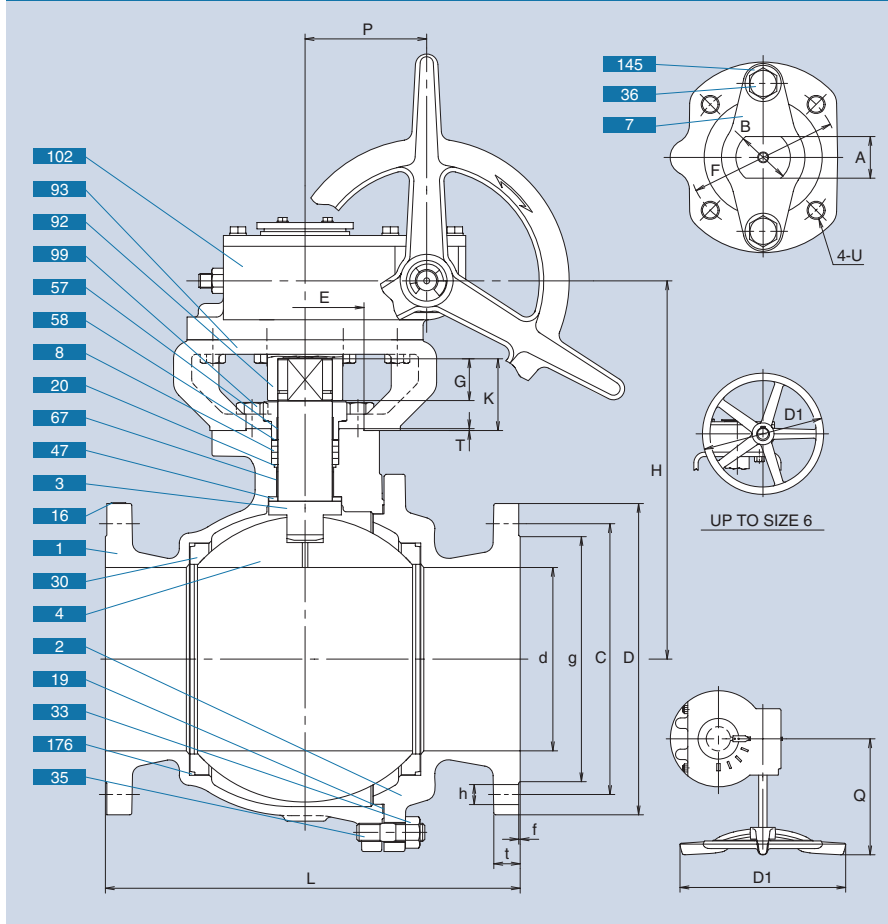

Construction and Materials

No.	Parts	Stainless steel shell	Carbon steel shell
		G-150UTDZ 5HM	G-150SCTDZ 5HM
1	Body	A351 Gr.CF8M	A216 Gr.WCB
2	Body cap	A351 Gr.CF8M	A216 Gr.WCB
3	Stem	A564 Type 630	
4	Ball	A276 Type 316 with Cr. plating	
7	Gland	A351 Gr.CF8	
8	Gland packing	Flexible graphite	
16	Name plate	A276 Type 304	
19	Gasket	Flexible graphite	
20	Packing washer	A276 Type 316L	
30	Ball seat	A276 Type 316 with Ni-Cr alloy hard facing*1	
33	Cap nut	A194 Gr.8M	A194 Gr.2HM
35	Cap bolt	A193 Gr.B8M	A193 Gr.B7M
36	Gland bolt	Stainless steel	
47	Thrust washer	Carbon	
57	Gland bush	Carbon	
58	Gland washer	A276 Type 304	
67	Stem bearing	Carbon	
92	Connector	Carbon Steel	
93	Bracket	Ductile Iron	
99	Bolt	Stainless Steel	
102	Gear unit		
126	Stopper plate bolt	Stainless steel	
145	Coned disc springs	Inconel® 718 or Equivalent	
176	Seat packing	Flexible graphite	

*1) Equivalent to METCO Type 16C

Dimensions:G-150UTDZ 5HM, G-150SCTDZ 5HM

Unit: inch

Nominal size	d	H	D1	L	End flange							Mounting Dimension for Actuator										APPROX. MASS (lb)		
					D	Bolt hole			Bolt size	g	t	f	P	Q	A	B	E	F	G	K	T		U	ISO5211 Flange Type
in.					C	NO.	h																	
5	4.84	11.89	14.17	14.00	10.0	8.50	8	0.88	3/4	7.31	0.94	0.06	3.48	8.27	1.06	1.42	3.35	4.92	1.06	2.05	0.08	M12	F12	194.01
6	5.95	13.19	14.17	15.50	11.0	9.50	8	0.88	3/4	8.50	1.00	0.06	3.48	8.27	1.42	1.89	3.94	5.51	1.42	2.48	0.08	M16	F14	264.56
8	7.95	16.42	19.69	18.00	13.5	11.75	8	0.88	3/4	10.62	1.12	0.06	5.28	14.84	1.81	2.36	5.12	6.50	1.81	3.11	0.08	M20	F16	467.38

Dimensions:G-150UTDZ 5HM, G-150SCTDZ 5HM

Unit: mm

Nominal size	d	H	D1	L	End flange							Mounting Dimension for Actuator										APPROX. MASS (kg)		
					D	Bolt hole			Bolt size	g	t	f	P	Q	A	B	E	F	G	K	T		U	ISO5211 Flange Type
mm					C	NO.	h																	
125	123	302	360	356	254	216.0	8	22	3/4	186	23.9	1.6	88.5	210	27	36	85	125	27	52	2	M12	F12	88
150	151	335	360	394	279	241.5	8	22	3/4	216	25.4	1.6	88.5	210	36	48	100	140	36	63	2	M16	F14	120
200	202	417	500	457	343	298.5	8	22	3/4	270	28.6	1.6	134.0	377	46	60	130	165	46	79	2	M20	F16	212